

Rotational Position Transducer

CANbus • SAE J1939

Ranges: 0-45° to 0-200 Turns

Industrial Grade

RT8CN

Specification Summary:

GENERAL

Full Stroke Ranges 0-0.125 to 0-200 turns
 Electrical Interface CANbus SAE J1939
 Protocol Proprietary B
 Accuracy ± 0.30 to 0.15% full stroke
 Repeatability ± 0.02% full stroke
 Resolution ± 0.003% full stroke
 Enclosure Material powder-painted aluminum or stainless steel
 Sensor plastic-hybrid precision potentiometer
 Shaft Loading up to 10 lbs. radial and 5 lbs. axial
 Starting Torque (25°C) 2.0 in-oz., max
 Weight, Aluminum (Stainless Steel) Enclosure 3 lbs. (6 lbs.), max.

ELECTRICAL

Input Voltage 7 - 18 VDC
 Input Current 60 mA max.
 Address Setting (Node ID) 0..63 set via DIP Switches
 Baud Rate 125K, 250K or 500K set via DIP Switches
 Update Rate 10 ms. (20 ms. available—*contact factory*)

ENVIRONMENTAL

Environmental Suitability NEMA 4/4X/6, IP67/68
 Operating Temperature -40° to 185°F
 Vibration up to 10 G's to 2000 Hz maximum

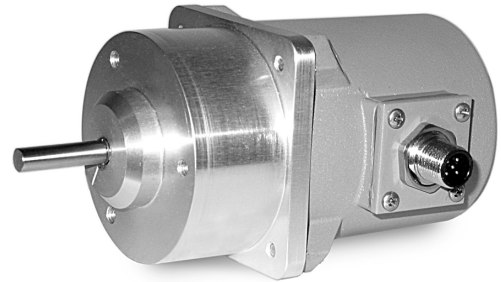

Celeco's model RT8CN communicates rotational position feedback to your PLC via the CANbus SAE J1939 interface. The heart of this sensor is a precision plastic-hybrid position potentiometer which provides a "absolute" position and does not ever have to be reset to a "home" position after a power loss or planned shutdown.

This innovative sensor from Celeco, designed to meet tough NEMA-4 and IP67 environmental standards, is available in full-stroke measurement ranges of 1/8 to 200 turns.

Outline Drawing

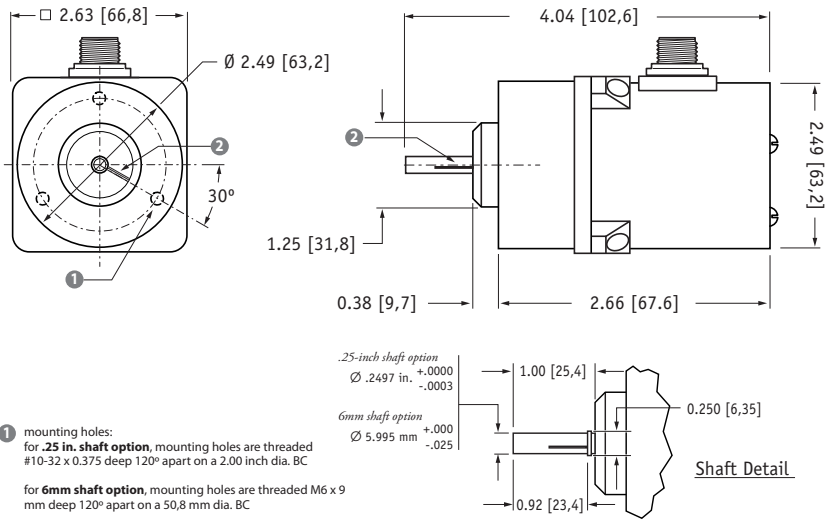

Output Signal

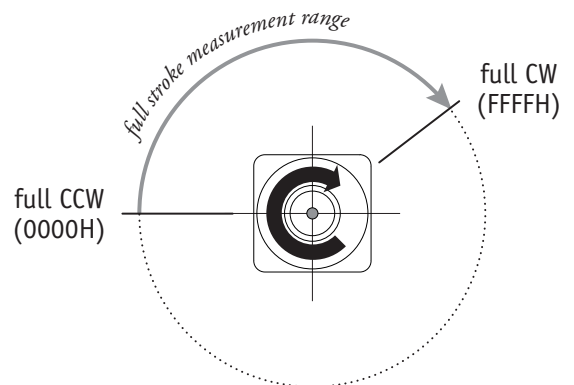

I/O Format:

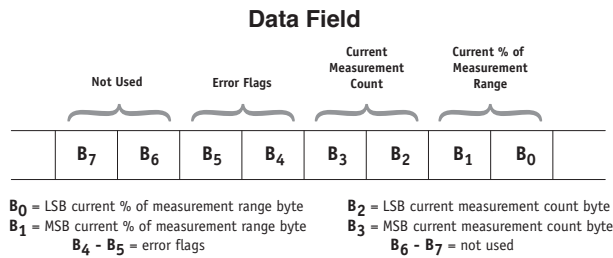
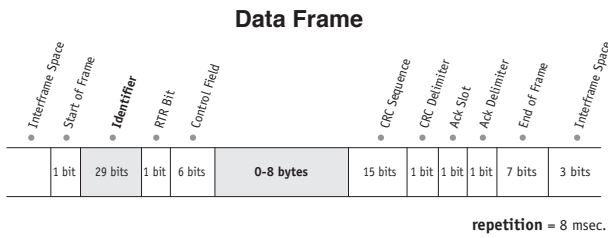

Identifier

	Message Priority			Future Use		J1939 Reference Proprietary B								Data Field Type*						Not Used		Node ID**								
Example -	1	0	0	0	0	1	1	1	1	1	1	1	1	0	1	0	1	0	0	1	1	0	0	1	1	1	1	1	1	1
Identifier Bit No. -	28	27	26	25	24	23	22	21	20	19	18	17	16	15	14	13	12	11	10	9	8	7	6	5	4	3	2	1	0	
Hex Value -	0			F		F								5						3		F								

*Sensor field data can be factory set to customer specific value. **Customer defined, set via Dips 1-6. Bit values shown for example only, see Address Setting below.

Setting the Address (Node ID) and Baud Rate

Address Setting (Node ID)

The Address Setting (Node ID) is set via 6 switches located on the 8-pole DIP switch found on the DeviceNET controller board located inside the transducer.

The DIP switch settings are binary starting with switch number 1 (= 2⁰) and ending with switch number 6 (= 2⁵).

Baud Rate

The transmission baud rate may be either factory preset at the time of order or set manually at the time of installation.

The baud rate can be set using switches 7 & 8 on the 8-pole DIP switch found on the DeviceNET controller board located inside the transducer.

DIP-1 (2 ⁰)	DIP-2 (2 ¹)	DIP-3 (2 ²)	DIP-4 (2 ³)	DIP-5 (2 ⁴)	DIP-6 (2 ⁵)	address (decimal)
0	0	0	0	0	0	0
1	0	0	0	0	0	1
0	1	0	0	0	0	2
...
1	1	1	1	1	1	63

DIP-7	DIP-8	baud rate
0	0	125k
1	0	250k
0	1	500k
1	1	125k

↑ = "0"
 ↓ = "1"

Current % of Measurement Range

The Current % of Measurement Range is a 2-byte value that expresses the current linear position as a percentage of the entire full stroke range. Resolution is .1 % of the full stroke measurement range.

This value starts at 0x0000 at the beginning of the stroke and ends at 0x03E8.

Example:	Hex	Decimal	Percent
	0000	0000	0.0%
	0001	0001	0.1%
	0002	0002	0.2%

	03E8	1000	100.0%

Current Measurement Count

The Current Measurement Count (CMC) is the output data that indicates the present position of the measuring cable.

The CMC is a 16-bit value that occupies bytes B₀ and B₁ of the data field. B₀ is the LSB (least significant byte) and B₁ is the MSB (most significant byte).

The CMC starts at 0x0000 with the measuring cable fully retracted and continues upward to the end of the stroke range stopping at 0xFFFF. This holds true for all ranges.

Error Flags

0x55 (yellow LED on controller board) indicates that the sensor has begun to travel beyond the calibrated range of the internal position potentiometer.

0xAA (red LED on controller board) indicates that the sensor has moved well beyond the calibrated range of the internal position potentiometer.

If either error flag occurs within the full stroke range of the sensor, the unit should be returned to the factory for repair and recalibration.

Converting CMC to Degrees

If required, the CMC can easily be converted a rotary measurement expressed in degrees instead of simply counts.

This is accomplished by first dividing the CMC by 65,535 (total counts over the range) and then multiplying that value by the FSR:

$$\left(\frac{\text{CMC}}{65,535} \right) \times \text{FSR}$$

Example:

If the full stroke range is 1 turn (360 degrees) and the current position is 0x0FF2 (4082 Decimal) then,

$$\left(\frac{4082}{65,535} \right) \times 360 \text{ degrees} = 22.4 \text{ degrees}$$

CANBus Controller Board and DIP Switch Location

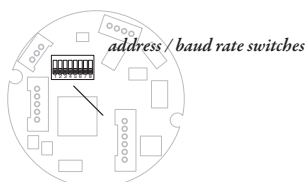

to gain access to the controller board, remove four Allen-Head Screws and separate case halves

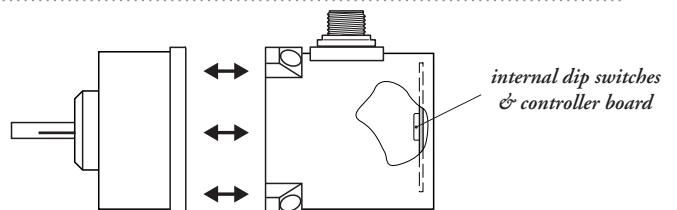

Ordering Information:

Baud Rate:

order code:	125	250	500
	125 kbaud	250 kbaud	500 kbaud

Node ID:

order code:	0	1	2	...	62	63
	select address (0 - 63 Decimal)					

Electrical Connection:

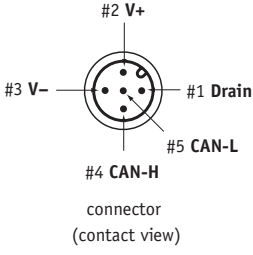
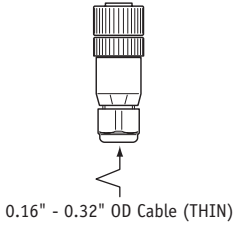
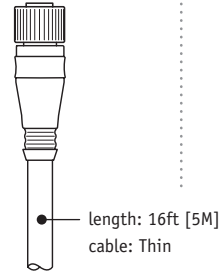
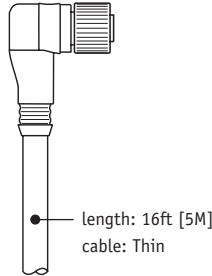
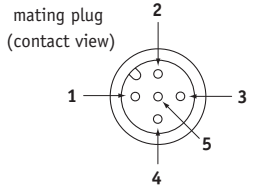
order code:	blank	MC5	SC5	NC5																		
	5-pin micro-connector <i>(no mating plug supplied)</i>	5-pin micro-connector w/ mating plug	5-pin micro-connector and 5 meter length cordset w/straight mating plug	5-pin micro-connector and 5 meter length cordset w/90° mating plug																		
	 <p>connector (contact view)</p>	 <p>0.16" - 0.32" OD Cable (THIN)</p>	 <p>length: 16ft [5M] cable: Thin</p>	 <p>length: 16ft [5M] cable: Thin</p>																		
		 <p>mating plug (contact view)</p>																				
			<table border="1"> <thead> <tr> <th>pin</th> <th>signal</th> <th>wire color</th> </tr> </thead> <tbody> <tr> <td>1</td> <td>drain</td> <td>brown</td> </tr> <tr> <td>2</td> <td>V+</td> <td>white</td> </tr> <tr> <td>3</td> <td>V-</td> <td>blue</td> </tr> <tr> <td>4</td> <td>Can-H</td> <td>black</td> </tr> <tr> <td>5</td> <td>Can-L</td> <td>grey</td> </tr> </tbody> </table>	pin	signal	wire color	1	drain	brown	2	V+	white	3	V-	blue	4	Can-H	black	5	Can-L	grey	
pin	signal	wire color																				
1	drain	brown																				
2	V+	white																				
3	V-	blue																				
4	Can-H	black																				
5	Can-L	grey																				